

# KBZ®

www.folangsiforklift.com

## ELECTRIC PALLET TRUCK 电动托盘搬运车

KBZ KBZ KBZ KBZ KBZ KBZ KBZ KBZ KBZ KBZ KBZ KBZ KBZ

### CBD20-TN

DC 2000Kg

- ▶ 1.AC vertical driving motor reduces the failure rate and saves maintenance cost.
- ▶ 2.Electronic power steering system(EPS) for flexible and light turning improves the stability of electrical system.
- ▶ 3.Electronic reverse system guarantees operation safety,save the electric energy and protect hydraulic unit.
- ▶ 4.Pressurized vibration damping reduces the wheel skidding problems and increases operating comfort.

- ▶ 1. AC 电机，立式驱动，减少故障发生率，节约维护成本；
- ▶ 2. 电子助力转向 (EPS)，转弯灵活、轻便，提高电气系统稳定性；
- ▶ 3. 电子退位系统，保障作业安全，节约电能，保护液压装置；
- ▶ 4. 增压减震，减少驱动轮打滑现象，增加操作舒适度。



Electric Pallet Truck Expert

# KBZ®

www.folangsiforklift.com

## ELECTRIC PALLET TRUCK 电动托盘搬运车

KBZ KBZ KBZ KBZ KBZ KBZ KBZ KBZ KBZ KBZ KBZ KBZ KBZ

### SPECIFICATION

详细说明

	Unit	
<b>Feature 特性</b>		CBD20-TN
Model 型号		150
Configuration No. 配置号		2000
Load capacity 额定载重	kg	600
Load center 载荷中心距	mm	1390
Wheel basenter 轴距	mm	Walkie
Operating type 操作类型		PU
Wheels type 车轮类型(前/后)		1/1/4
<b>Wheels 车轮</b>		
Wheel quantity Driving wheel/Balance wheel/Bearing wheel 驱动轮/平衡轮/承重轮数量		mm
Driving wheel size 驱动轮尺寸	mm	c 248 × 75
Bearing wheel size 承重轮尺寸	mm	c 80 × 80 ( Double Pulley)
Balance wheel size 平衡轮尺寸	mm	c 115 × 55
<b>Demension 尺寸</b>		
Lowered fork height 货叉最低离地高度	mm	85
Max. lifting height 货叉最大起升高度	mm	195
Max. lifting Route 最大起升行程	mm	110
Outside width between forks 货叉外侧间隙	mm	540/600/685
Fork Length 货叉长度	mm	1150/1200
Fork width 货叉宽度	mm	185
Fork thickness 货叉厚度	mm	55
Overall length 整车全长	mm	1750
Overall width 车体宽度	mm	720
Overall height(with handle) 整车高度(含手柄)	mm	1385
Overall height(without handle) 整车高度(不含手柄)	mm	850
Min.Turning radius 最小转弯半径 踏板收起/放下	mm	1575
Min.Aisle width for pallets 800 × 1200 最小直角堆垛通道宽度	mm	1900
Min.Aisle width for pallets 1000 × 1200 最小直角堆垛通道宽度	mm	1940
<b>Performance 性能</b>		
Travel speed,laden/unladen 最大行驶速度 满载/空载	km/h	4/4
Lift speed,laden/unladen 最大起升速度 满载/空载	mm/s	56/60
Travel speed,laden/unladen 最大下降速度 满载/空载	mm/s	57/59
Gradeability,laden/unladen 爬坡速度 满载/空载	%	5/7
<b>Electrical configuration 电气配置</b>		
Drive motor 驱动电机	KW	AC 1.5
Lift motor 起升电机	KW	DC 2.0
Steering motor 转向电机	KW	DC 0.15
Battery voltage/capacity 蓄电池电压/容量	V/Ah	24/210
Brake 制动		Electromagnetic/Regenerative
Controller 控制器型号		CURTIS
<b>Weight 重量</b>		
Battery weight 蓄电池重量	kg	190
Service weight with battery 自重(包含蓄电池)	kg	600

### DIMENSION DRAWING 外形尺寸图

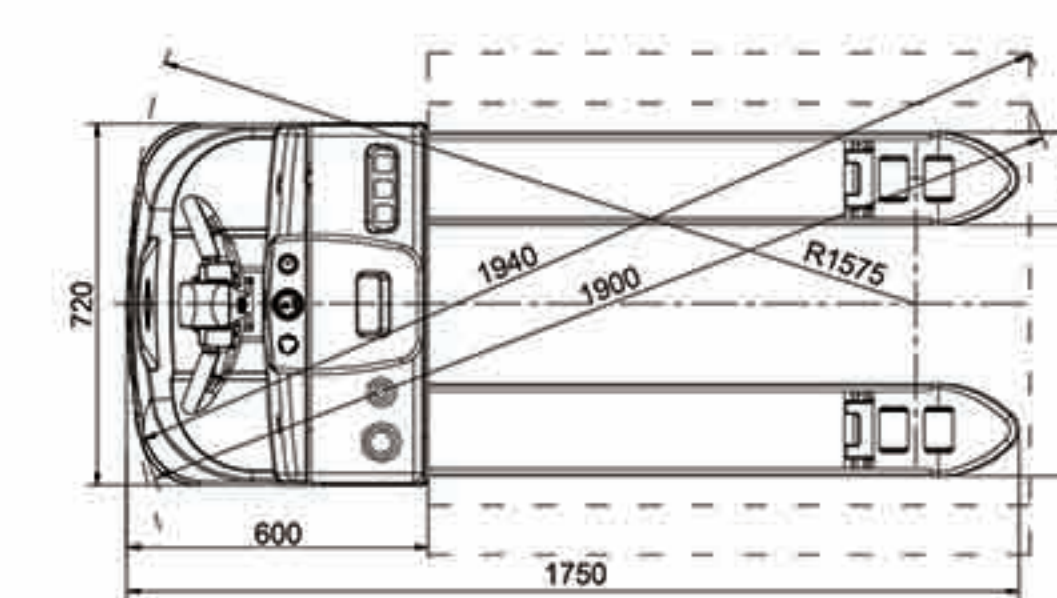
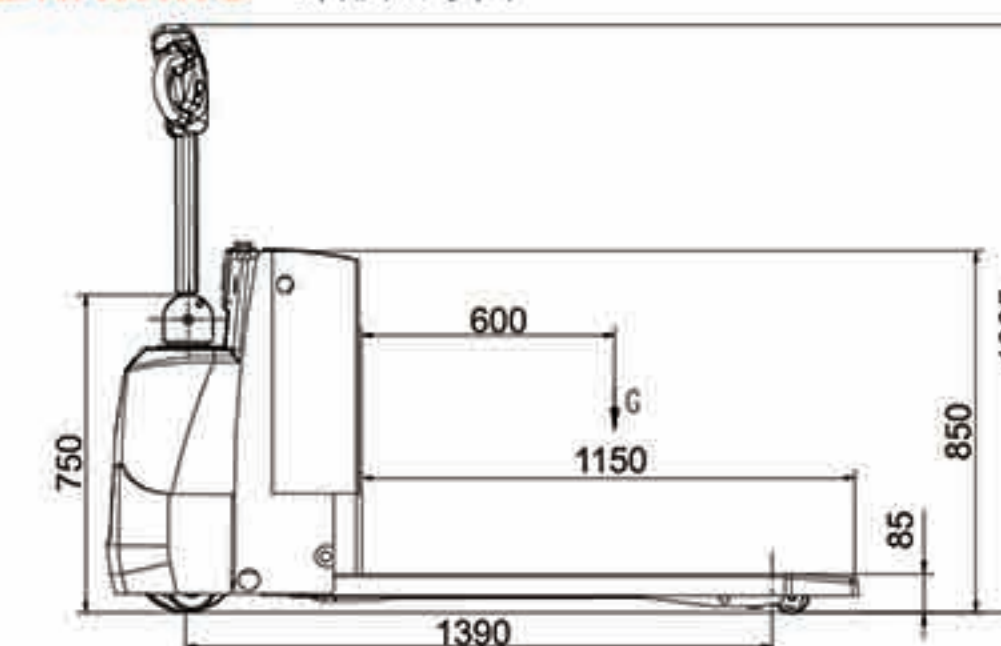

FOLANGSI MACHINE CO., LTD.

Tel.:020-39993595 Fax:020-39993597

E-mail:admin@folangsiforklift.com

# KBZ®